

TPL 121600

12V 160.0Ah

TPL 121600 is a general purpose battery with 10 years expected life under normal float charge. As with all CSB batteries, all are rechargeable, highly efficient, leak proof and maintenance free.



Specification

Nominal Voltage	12
Capacity 25 °C (77°F)	160Ah @ 8hr-rate to 1.75V per cell
Dimensions	Height : 320mm (12.6inch) Length : 557mm (21.9inch) Width : 124.8mm (4.90inch)
Weight	Approx. 56kg (123 lbs)
Internal Resistance	Approx. 4.0mΩ
Flame Retardant Container / Cover UL - Laboratories Rating	UL94-V0(PP)/L.O.I higher than 28 .
Float Charging 25°C (77°F)	2.275±0.025V Temperature coefficient -3.3mV/°C (1.8mV/°F)
Maximum Discharge Current in 5 seconds	800A
Maximum Charge Current (C/5)	45A
Service Temperature Rang	Discharge: -15 °C ~ 50°C (5°F ~ 122°F) Charge: -15°C ~ 40°C (5°F ~ 104°F) Storage: -15°C ~ 40°C (5°F ~ 104°F)
Terminal Type	Threaded copper alloy insert terminal to accept 1/4"-20bolt
Terminal Hardware Initial Torque	110-in-lbs. (12.4 N-m)



CSB-manufactured batteries are UL-recognized components under UL924 and UL1989. CSB is also certified by ISO 9001 and ISO 14001.

Dimensions

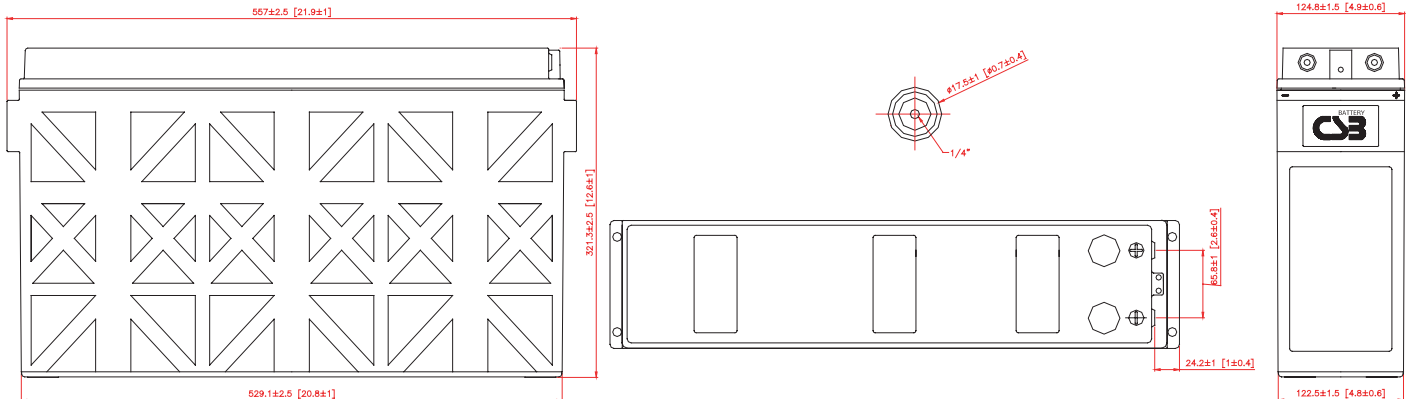

Constant Power Discharge Characteristics Unit:Amperes (25°C,77°F)

F.V/Time	15MIN	30MIN	1HR	2HR	3HR	4HR	5HR	6HR	7HR	8HR	10HR	20HR
1.67V	296.80	188.50	110.50	64.20	47.30	38.10	31.60	27.00	23.50	20.80	17.00	8.90
1.70V	284.60	184.80	109.50	63.50	46.80	37.60	31.20	26.60	23.20	20.40	16.80	8.80
1.75V	263.60	176.10	107.50	62.50	45.50	36.50	30.00	25.60	22.40	20.00	16.40	8.60
1.80V	237.30	165.40	103.00	60.80	44.10	34.80	29.00	25.00	21.70	19.30	15.90	8.40
1.83V	216.20	155.70	98.70	59.10	42.50	33.80	28.20	24.30	21.10	18.70	15.40	8.20
1.85V	203.30	149.40	95.30	57.70	41.50	33.10	27.50	23.70	20.70	18.40	15.20	8.00
1.90V	168.10	125.70	82.30	51.30	37.80	30.00	25.00	21.30	18.80	16.80	13.90	7.40

Constant Power Discharge Characteristics Unit:Watts (25°C,77°F)

F.V/Time	15MIN	30MIN	1HR	2HR	3HR	4HR	5HR	6HR	7HR	8HR	10HR	20HR
1.67V	3,150.53	2,035.80	1,211.08	713.26	530.23	428.82	356.61	304.99	265.67	235.25	192.44	101.02
1.70V	3,045.22	2,014.32	1,209.98	711.84	529.07	426.76	354.90	302.84	264.36	232.56	191.69	100.67
1.75V	2,873.24	1,947.67	1,206.69	710.31	521.43	419.93	345.75	295.42	258.72	231.00	189.58	99.67
1.80V	2,636.40	1,856.62	1,174.20	702.24	512.22	405.77	338.72	292.25	253.89	225.91	186.19	98.62
1.83V	2,430.09	1,765.64	1,138.50	688.81	497.89	397.32	331.91	286.25	248.77	220.57	181.80	97.01
1.85V	2,304.41	1,707.64	1,105.48	676.53	489.08	391.24	325.46	280.73	245.30	218.13	180.35	95.12
1.90V	1,933.15	1,461.26	969.08	610.21	451.71	359.25	299.75	255.60	225.69	201.77	167.08	89.10

● All mentioned values are average values.

Trickle (or Float) Service Life

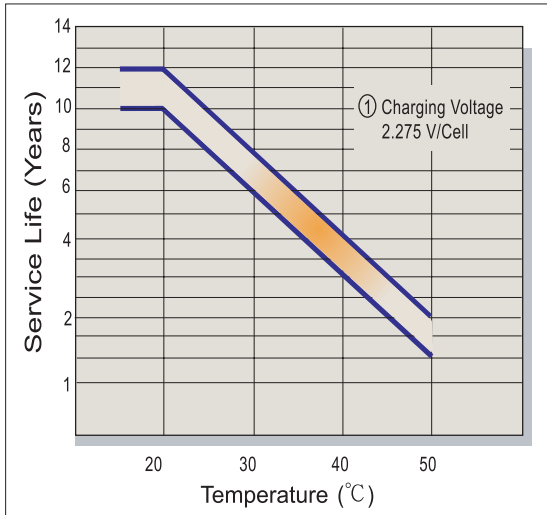

Capacity Retention Characteristic

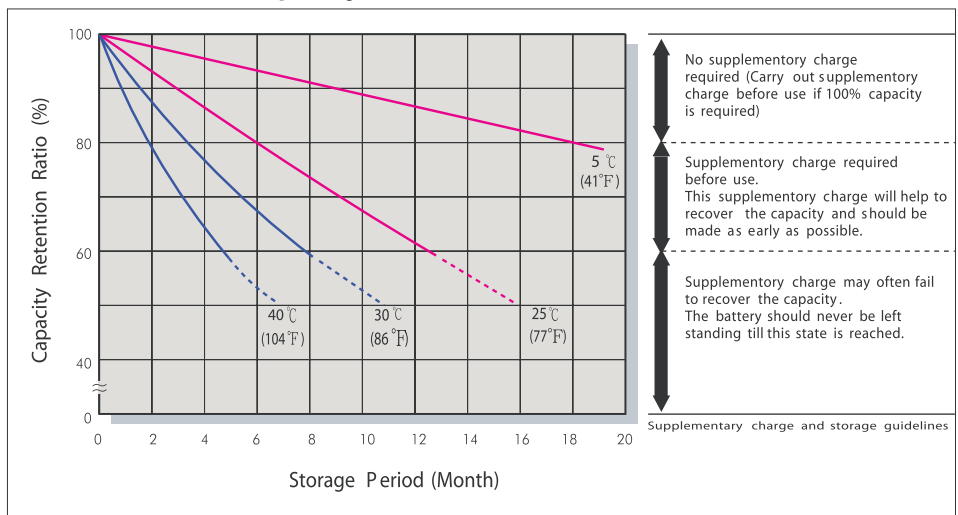

Battery Voltage and Charge Time for Standby Use

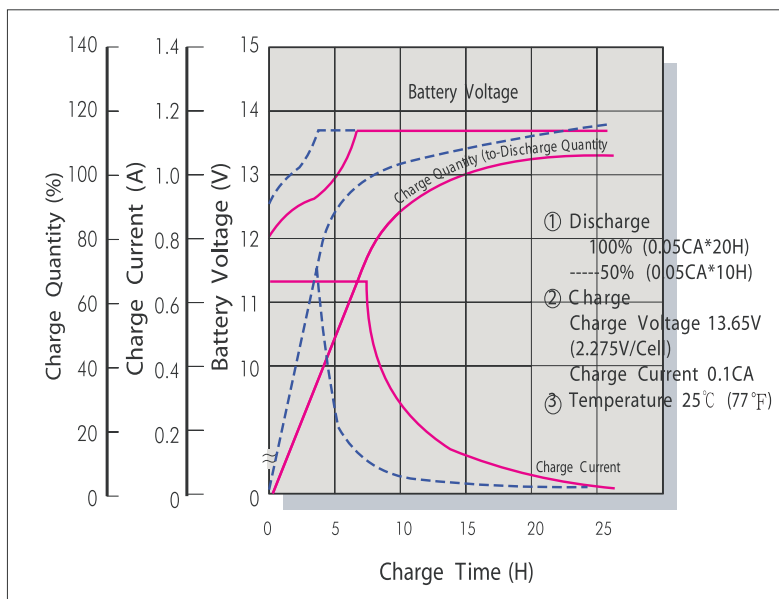

Terminal Voltage (V) and Discharge Time (25°C/77°F)

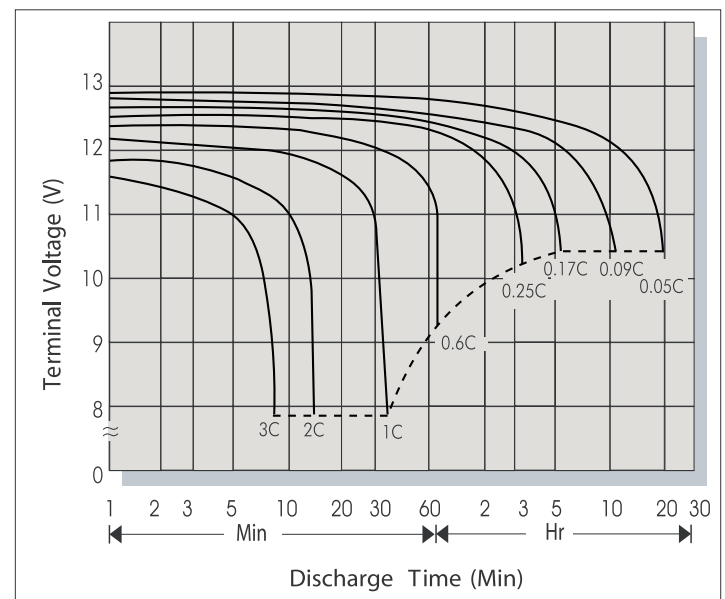

Battery Voltage and Charge Time for Cycle Use

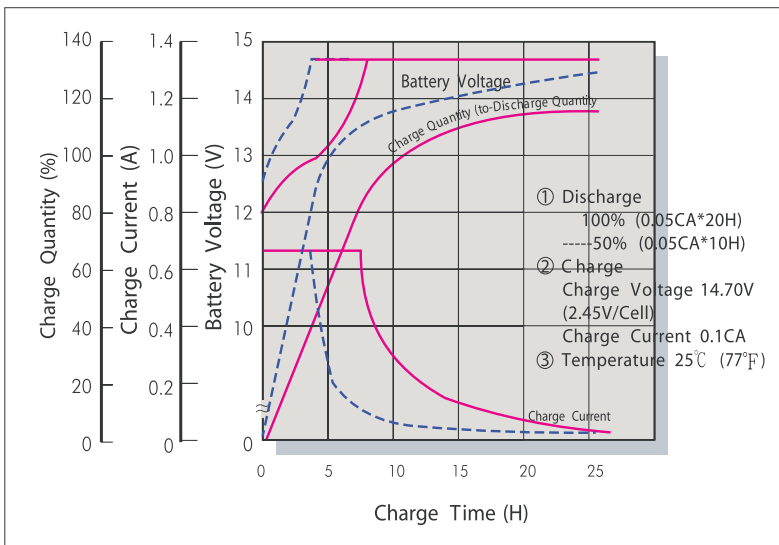

Discharge Current VS. Discharge Voltage

Final Discharge Voltage V/Cell	1.75	1.70	1.55	1.30
Discharge Current (A)	0.2C >(A)	0.2C <(A)<0.5C	0.5C <(A)<1.0C	(A)>1.0C

Charging Procedures

Application	Charge Voltage (V/Cell)			Max. Charge Current
	Temperature	Set Point	Allowable Range	
Cycle Use	25°C(77°F)	2.45	2.40~2.50	0.3CA
Standby	25°C(77°F)	2.275	2.25~2.30	

Sales Office URL: WWW.CSB-BATTERY.COM

CSB BATTERY CO., LTD.
TAIWAN OFFICE
Tel: +886-2-8751-5000
Fax: +886-2-8751-6161
E-mail: service@csb-battery.com.tw

CSB BATTERY LOGISTICS (SHANGHAI) CO., LTD.
SHANGHAI OFFICE
Tel: +86-21-5046-1622, 5046-0833
Fax: +86-21-5064-3314

CSB BATTERY TECHNOLOGIES, INC
USA OFFICE
Tel: +1-817-244-7777/1-8003 CSBUSA(272872)
Fax: +1-817-244-4445
E-mail: csb@csb-battery.com

CSB BATTERY LOGISTICS (SHANGHAI) CO., LTD.
BEIJING OFFICE
Tel: +86-10-6597-8060, 6597-8070
Fax: +86-10-6597-8050
E-mail: chinasl@csb-battery.com

CSB BATTERY OF NETHERLANDS B.V
NETHERLANDS OFFICE
Tel: +31(0) 180 418 140
Fax: +31(0) 180 418 327
E-mail: eurosales@csb-battery.com

CSB BATTERY LOGISTICS (SHANGHAI) CO., LTD.
SHENZHEN OFFICE
Tel: +86-755-88316356 88316488 88316396
Fax: +86-755-88316548
E-mail: she@csb-battery.com